



# COMPANY PROFILE



The first and only in-Kingdom pipe supports manufacturer and field services provider



ARAMCO-approved manufacturer and contractor

أرامكو السعودية  
saudi aramco



# Contents

Introduction.....	2-3
Mission + Vision + Strengths.....	4
Organizational Structure (KEKSA).....	5
Our Products.....	6-8
Our Services.....	9-10
Client's Recommendation.....	11
Key Contacts.....	12
Clients + End Users .....	13-14
Address .....	15







## Introduction



Kinetic Energy Factory Company – KEKSA is a subsidiary of AMCDE, which is one of the first Saudi Aramco approved licensed engineering firms in Kingdom of Saudi Arabia. AMCDE's growth and reputation has been stellar and it has grown into various organizations including a JV with KBR under the banner of KBR-AMCDE and more recently into the further diverse AHCEC & AMCL.

**KBR - AMCDE** has been established with a vision of developing its services to cover all the Saudi Hydrocarbon sector, then to expand to other sectors within Saudi Arabia and beyond as opportunities arose in the region and as capacity was built. Currently, KBR-AMCDE is providing multi discipline engineering services including conceptual design, detailed design, and project management in a fashion that meets Saudi Aramco's high quality requirements and procedures.



is providing a full range of engineering services including conceptual design, front – end engineering design, detailed design, and project management. AHCEC is handling Architectural & Building Services, Urban Planning, Geographical Information Systems (GIS) & Survey, Traffic & Transportation, Power Transmission & Distribution and Project Management – Construction Supervision – Manpower Supply projects.



was created to leverage the knowledge and experience the owners have amassed over four decades in serving the market in the engineering services arena to diversify their portfolio of services and investments. The vision is to serve the local market by entering into partnerships & joint ventures (JVs) with other local and international companies that are not only experienced in their appropriate fields, but are also reputable by the quality of their services. The services that AMCL is targeting to offer through the various JVs and partnerships are: EPC's, Technical support services, manufacturing of specialized elements for the industrial sector and etc.

AMCDE has analyzed the increasing demands of pipe supports in GCC and has kept the vision in mind to manufacture pipe supports locally. In 2007, AMCDE has established KEKSA with a state-of-the-art manufacturing facility in the Industrial Hub of KSA. KEKSA specializes in manufacturing Spring Hangers and all kinds of Pipe supports for the harsh local environments and demanding applications of the petrochemical, oil, gas, power generation, LNG, renewable energy and water treatment industries. With the passage of time, through executing projects for BAPCO, Saudi Aramco, SEC, SABIC, MA'ADEN, KNPC, Qatar Petroleum, Kuwait Oil Company, Rabigh Power Company, Turkmengas, YASREF and others, KEKSA has garnered a reputation for reliability, quality, and project execution excellence.



As a Saudi local-based company, KEKSA provides reliable and quality pipe supports at competitive prices with shorter delivery times, having fewer customs hurdles than the competition for the GCC market. KEKSA also provide field services related to pipe supports. Being local results in quick response time for emergencies including inspection and adjustment, installation and commissioning, testing and calibrating for pipe supports.

With the engineering capabilities in the group, a local manufacturing facility and readily available service team, KEKSA ensures to cover complete requirements of clients for pipe supports.



In 2016, KEKSA formed a strategic partnership with Bergen Pipe Supports (BPS), part of Hill & Smith Holdings PLC, a UK based international group with leading positions in the supply of infrastructure products and galvanizing services to global markets.

Established in 1968, Pipe Supports Group is a global manufacturer and supplier of pipe supports and restraint equipment to the power generation, oil, gas, petrochemical, LNG renewables and waste water industries with manufacturing Centers of Excellence in USA & India.

This strategic alliance brings forth the strength of both organizations so as to benefit the customers in the Gulf Cooperation Council (GCC) and Middle East regions. KEKSA contributes by being a local Saudi Arabian establishment with experience in the regional conditions and BPS bring forth their experience as an international specialist and a global supplier of pipe supports. BPSL has a manufacturing center of excellence and brings its vast experience and extensive product range to the partnership.



**BERGEN PIPE SUPPORTS (USA)**



**BERGEN PIPE SUPPORTS (India)**

## + Mission + Vision + Strengths

### Giving you the Best Piping Systems Support



### Our Mission

KEKSA's core purpose is to offer superior-quality pipe supports and services to the GCC market. We maintain our strong reputation as a local company through offering localized expertise, competitive prices, shorter delivery times, and world -class quality.

### Our Vision

To become the premier pipe supports manufacturer and services provider in KSA, the GCC, and the greater Middle East by nurturing our partnerships, building on our client base, and creating long-term value for the petrochemical, oil, gas, and power generation industries. KEKSA aims to be recognized as the key Partner to keeping these industries up and running.

### Our Strengths

As a local manufacturer and services provider, KEKSA:

- Offers high quality pipe supports for the GCC at competitive prices
- Offers local field services with quick response time for emergencies
- Ensures shorter delivery times and fewer customs hurdles than facilities in Europe, U.S., & Asia
- Strategic Partner – Bergen Pipe Supports Ltd.

# + Organizational Chart

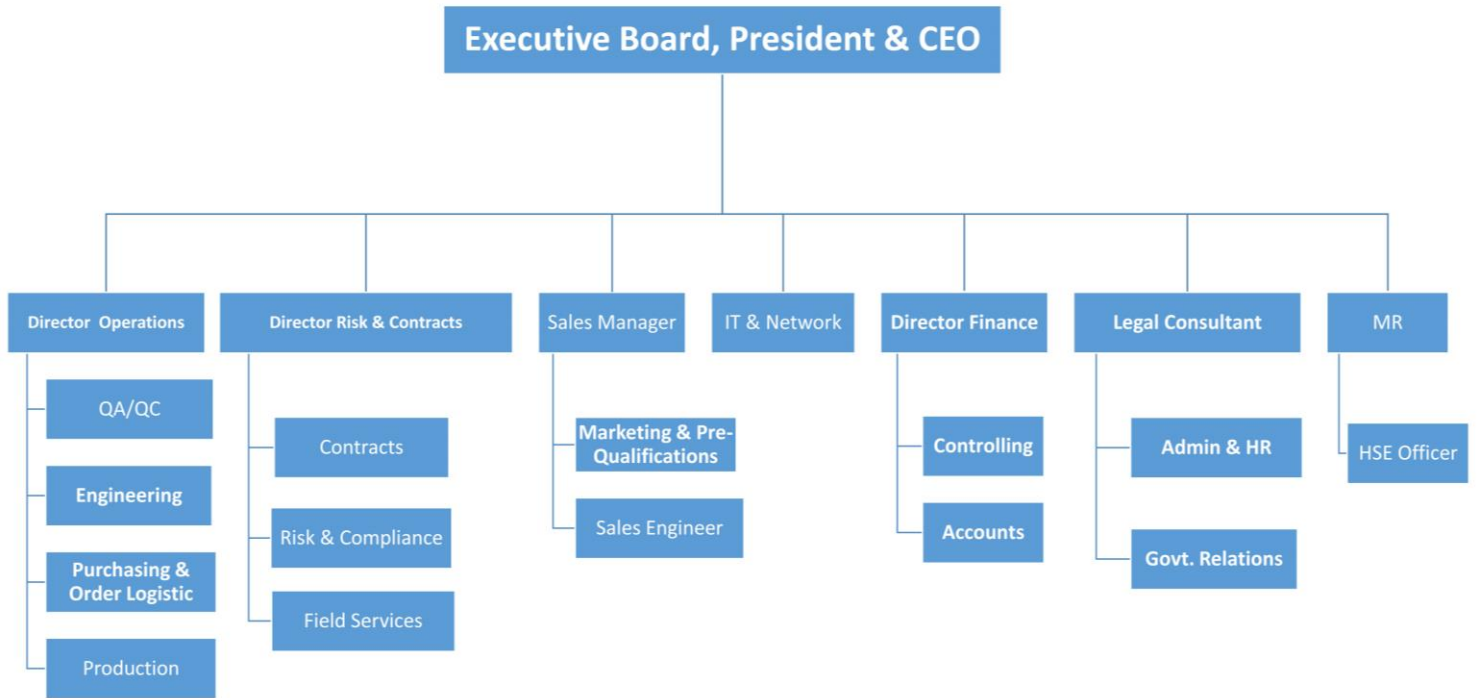





## Our Products

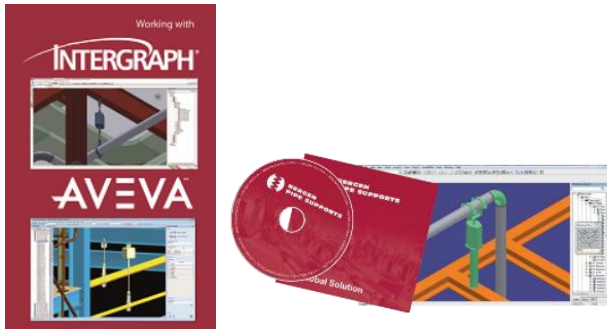

### Design Software PS Designer

The Pipe Supports Group supplies its customers with specialist pipe support software which fully integrates with major plant design packages including Aveva's PDMS/E3D and Intergraph's Smart 3D, making hanger design and selection much easier.

PS Designer, the most comprehensive 3D pipe support package, saves time and reduces error for customers whilst providing a range of special features such as intelligent selection and clash detection.

Our latest PSDesigner software will aid the creation and design of cryogenic supports helping to reduce time for quotations and delivery.



### Constant Hangers and Supports

Constant Supports are used to support pipework or equipment with an essentially constant supporting effort during what may be large vertical movement. Where the change in supporting effort which occurs when using variable effort supports is unacceptable, or where the amount of travel provided by variable supports is insufficient, constant supports should be specified.

High-temperature steam lines in power stations and flow lines on oil production platforms are examples of situations where large relative movement between piping and the supporting structure make the use of Constant Effort Supports essential.

Constant Supports can also be custom-made to client's specifications and hot dip galvanized to withstand the GCC climate. Metric and Imperial Catalogs are available.



### Spring Hangers and Supports

Variable Supports are used to support the weight of pipework or equipment whilst allowing a degree of movement relative to the supporting structure. Where pipes transport hot (or cold) liquids or gases they expand (or contract) due to the difference between operating and ambient temperatures. It is necessary to support the pipe in operating and ambient conditions, whilst permitting movement between the two.

Variable Supports can also be custom-made to client's specifications and hot dip galvanized to withstand the GCC climate. Metric and Imperial Catalogs are available.



### Rigid Struts & Snubbers

In pipework systems that are subject to dynamic loading, it may be necessary to use Rigid Struts and Snubbers. Dynamic loading may occur for a number of reasons. Unsteady flow, such as that caused by sudden valve closure, produces dynamic forces and is referred to as water hammer. In an earthquake, a piping system is also subject to dynamic forces.

Rigid Struts act in both directions, rather than hanger rods, which only support downward acting loads. Rigid Struts are also used to provide lateral restraint where this is required.

Snubbers are used where sudden dynamic restraint is required, but the pipe has to be allowed to gradually move thermally. Metric and Imperial Catalogs are available.

### Pipe Connection Parts



Pipe clamps, clamp bases, weld -on lugs, and U-bolts are essential as pipe connection components. They are highly stressed in high temperature piping systems and therefore must be of high quality. These components and the loads they cover, comprise a broad spectrum of the practical field of application. Clamps can be designed for operation in temperatures up to 650°C.

Pipe bearings and saddle components are ideal as supports for piping systems arranged horizontally over long stretches. To allow normal thermal movement, the support points are designed as either sliding or roller types.

### Cryogenic Supports



Cryogenic pipe supports are used in cold temperature applications. These supports are made of High-Density Polyurethane Foam (HD PUF). Anchors and stops can be supplied with fitted spools, ready for installation on site.

Our close relationship with chemical specialists enable us to produce rigid-high density polyurethane in densities ranging from 100 to 600kg/m<sup>3</sup>. The chemical is completely CFC and HCFC free and gives extremely low thermal conductivity combined with good compressive, flexural and tensile strength properties.

### Connecting Elements



Connecting Elements are the hardware that complement spring supports and allow the connection of the pipe to the building structure. These include threaded connecting elements like clevises, turnbuckles, eye nuts, rod couplers, and hanger rods. All components are drop forged, and designed (apart from turnbuckles) to allow slight length adjustments, despite their limited installation height.

### Customized Supports

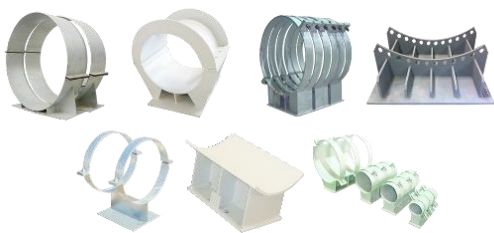

KEKSA offers wide range of engineering solutions to our customers. We are also capable of designing and delivering customized pipe supports as per project requirements. We are equipped to meet the special surface protection requirements of projects.



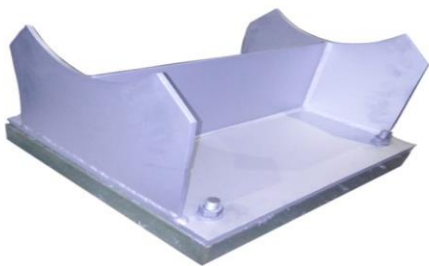
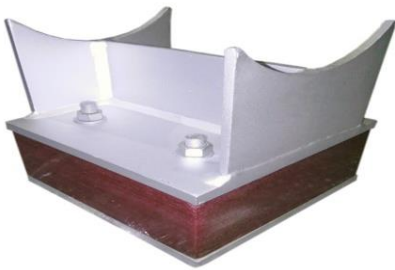
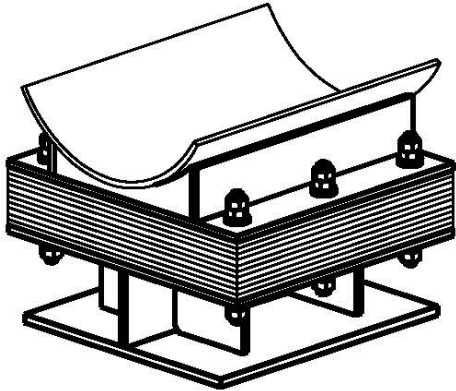

## BERGATHERM

Bergatherm is the range of Composite blocks, manufactured by Bergen & affiliates, using high strength glass fabrics and specially formulated epoxy resin and developed for cryogenic and other similar and demanding applications.

We use a highly sophisticated vacuum infusion manufacturing process to ensure the resin impregnates fully and any possibility of air entrapment is totally eliminated. Air entrapment is a common problem in products made using conventional open contact moulding processes and the Infusion process adapted by us ensures consistent and uniform laminate properties across the product.

After completing the Infusion, blocks are suitably post cured and then precision machined on CNC machining centers to ensure extremely accurate drilling location and dimensional accuracy.

The material selection has been carefully done to achieve very superior mechanical and thermal properties for critical applications in the cryogenic environment.

Typical Properties of **Bergatherm** Composite Blocks are tabulated below:

Property	Unit of Measurement	Applicable Standard	Specifications
Specific gravity	gm/cm <sup>3</sup>	ISO 1183	1.80 ~ 1.95
Water Absorption	%	ISO 62	< 0.30
Glass Content	% by Weight	ISO 11358	60 ~ 70
Tensile Strength	N/mm <sup>2</sup>	ISO 527-4/5	> 100
Compressive Strength	N/mm <sup>2</sup>	ISO 604	> 300
Impact strength un-notched	KJ / m <sup>2</sup>	ISO 180	>80
Thermal conductivity RT	W/mK	ISO 22007-2	< 0.30
Flammability	Seconds	UL-94	V0/ <50
Thermal Classification	°C	-	-196 to +150

Additional Tests and Testing at different standards can also be conducted by prior agreement to specific customer requirements.

This data has been achieved under controlled circumstances. The user must assure himself of the suitability of the material for use in specific environments & conditions.



## + Our Services

KEKSA services will make a valuable contribution to the functional safety and longevity of pipe supports and avoid costly damages or shutdown of the plant.

### Field Service Objectives:

- Increase operational safety
- Guarantee plant availability
- Prevent costly shut-downs and damage
- Secure long life of pipe supports

### Site Surveys and Inspection

To avoid costly damage and operational breakdown the regular inspection of thermal movement in piping systems and the condition of supports - especially in older installations - is widely encouraged. Our engineers will produce comprehensive reports and provide the appropriate recommendations for a solution if needed.

### Installation & Commissioning Supervision

Most mistakes in piping supports are made during installation and commissioning. Our engineers will supervise installation of piping systems into the supports prepared, inspect the system for correct installation according to drawings, de-block and commission the supports, conduct load and travel checks after commissioning, and inspect for freedom of movement of the pipe system in all three planes.

### Maintenance, Testing & Calibrating

Our engineers will conduct maintenance based on inspection findings, as well as preventive maintenance (PM). To ensure the mechanical integrity and functionality of spring supports, it is recommended to conduct PM on all pipe supports at every planned shutdown. Our engineers will also calibrate spring supports at our testing facility if required.

Field Survey & Inspection



Installation & Commissioning



Testing & Maintenance





# Site Survey Discoveries



Corrosion worsened by painting rather than by using HDG.



Completely rusted Spring Hangers after years of services.



Corrosion worsened by painting rather than by using HDG.



Load adjustment required as per name plate.



Corrosion worsened by painting rather than by using HDG.



Blocking of Spring Hanger was done incorrectly. Hanger is misaligned due to the absence of a base plate. Hanger Rod is bent due to misalignment of Spring Hanger.



Improper installation – blocking not removed properly.



Stress Analysis not done properly, huge misalignment causing breakage.





## Client Recommendations



"During the project, KEKSA displayed full commitment towards quality and delivery for all the products provided. Their local presence in the Kingdom of Saudi Arabia has simplified and streamlined technical discussions which have in turn enabled us to execute the project within the window of a very aggressive time schedule."

**-- Hamad Al Rashidi, Director of Projects & Expansion  
Dept., Ma'aden Phosphate Company**



"KEKSA's approach to the project was one of complete Professionalism throughout. Their communication skills for the duration of the contract, the submission and quality of their documentation and their ability to perform under pressure were essential to the timely completion of the project. We would welcome the opportunity to work with them on future projects."

**-- Sukru Aytemiz, Project Manager, Tekfen Construction**



## Key Contacts

The contact information of selected Departments is located below to ensure clear and easy communication between KEKSA and our clients.

### Sales, Marketing & Prequalification:

[SALES@KEKSA.COM](mailto:SALES@KEKSA.COM)

### Engineering & Manufacturing:

[ENGINEERING@KEKSA.COM](mailto:ENGINEERING@KEKSA.COM)

### Compliance & Customer Care:

[INFO@KEKSA.COM](mailto:INFO@KEKSA.COM)



## Our Clients (End Users)





+

## Our Clients (Contractors)





## Address & Contacts

### Kinetic Energy Factory Company - KEKSA

#### Head Office:

AMCDE Building  
Prince Sultan Bin Abdulaziz Road, Rakah  
Al-Khobar-Dammam Highway  
P.O. Box 3594, Al-Khobar, 31952  
Kingdom of Saudi Arabia  
Tel : +966 (13) 8588877 Ext. 453 or 483  
Fax : +966 (13) 858 8866

#### Plant:

Jubail Support Industrial Area  
Al-Jubail, Kingdom of Saudi Arabia  
Tel : +966 (13) 341 8899 Ext. 124/129/145/150  
Fax: +966 (13) 341 7799

**Website:** [www.keksa.com](http://www.keksa.com)

**E-mail:** [info@keksa.com](mailto:info@keksa.com)

#### Bahrain Office:

Kinetic Energy Factory Company –KEKSA  
Office No.31, Building 602, Road 2018, Block 320  
Manama “Hoorah” - Kingdom of Bahrain.  
Tel: +973-172-30-389  
Fax: +966 (13) 341 7799

## Strategic Partner

#### Bergen Pipe Supports USA

Bergen Pipe Supports, Inc.  
225 Merrimac Street  
Woburn, MA 01801 USA  
Tel: +1 (0)781 935 9550  
Fax: +1 (0)781 938 0026  
E-mail: [bpw@pipesupports.com](mailto:bpw@pipesupports.com)

#### Bergen Pipe Supports India

Bergen Pipe Supports (India) Private Ltd.  
No. 720, Belerica Road Sector 22, Sri City DTZ  
Varadaiahpalem Taluk (Mandal) Chittoor District–  
517541 Andhra Pradesh India  
Tel: +91 8576 305666  
E-mail: [bpsl@pipesupports.com](mailto:bpsl@pipesupports.com)